

QUARTZ CRYSTAL



SERIES 6L SURFACE MOUNT PACKAGE FOR TUNING FORK

FEATURE

- Wide Frequency range
- Small size
- Tape & Reel

APPLICATIONS

- Microprocessor Systems
- Consumer Electronics

ELECTRICAL SPECIFICATIONS FOR 206A & 206B

Frequency range	30.000KHz ~ 200.000KHz
Frequency Tolerance (at 25°C)	±20ppm ~ ±100ppm, or specify
ESR	32KHz-40KHz: 40Kohm Max
	40KHz-60KHz: 30Kohm Max
	60KHz-70KHz: 25Kohm Max
	70KHz-100KHz: 22Kohm Max
	100KHz~ 200KHz: 20Kohm Max
Turnover Temperature	25 ± 5°C
Frequency Temperature Curve	-0.034(±0.006)ppm/°C ²
Storage Temperature Range	-55 °C to +125 °C
Operable Temperature Range	-40 °C to + 85 °C
Shunt Capacitance (C0)	2.0pF Typ
Dynamic Capacitance (C1)	4.0pF Typ
Driver Level (Typical)	1 μW Max
Load Capacitance(C _L)	6.0pF ~ 12.5pF, or specify
Aging @25°C 1 st year (Max)	±3ppm, ±5ppm/year

REMARK: SPECIFICATIONS SUBJECT TO CHANGE WITHOUT PRIOR NOTICE. PLEASE CONFIRM WITH OUR SALES ENGINEER.

ELECTRICAL SPECIFICATIONS FOR 308C-32.768KHz

Item	Sym.	Specification
Frequency	f _o	32.768KHz
Frequency Tolerance	Δf/f _o	+/-20PPM ~ +/-100ppm
ESR	R1	30Kohm ~ 50Kohms Max
Turnover	T _O	25°C +/-5°C
Quality Factor	Q	100 000 Typ
Frequency temperature stability		-0.034ppm/°C ² Max
Operating Temp	T	-10°C~+60°C / -40°C~+85°C
Insulation Resistance	IR	≥500 Mohm
Load Capacitance	CL	6.0pF ~ 12.5pF Type
Dynamic Capacitance	C1	2.4pF Type
Shunt Capacitance	C0	1.3pF Type
Driver Level	DL	1μ W Max
Aging	f _a	+/-3ppm /Year

QUARTZ CRYSTAL



SERIES 6L SURFACE MOUNT PACKAGE FOR TUNING FORK

PACKING AND DIMENSIONS

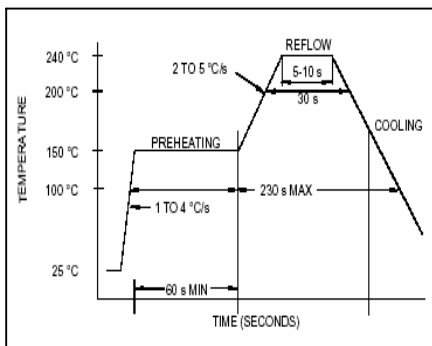
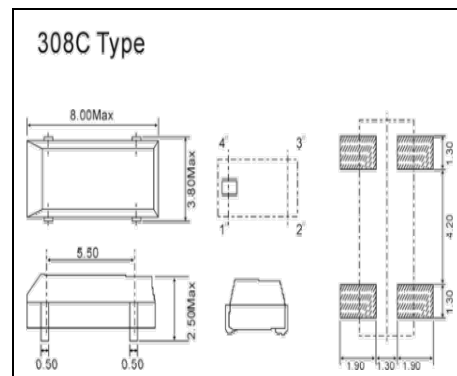
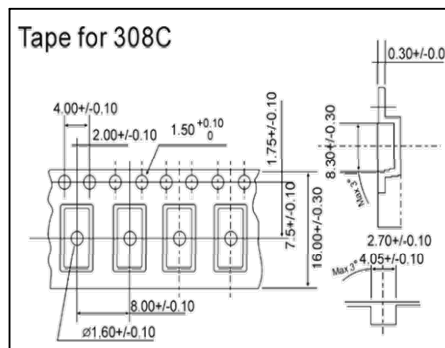
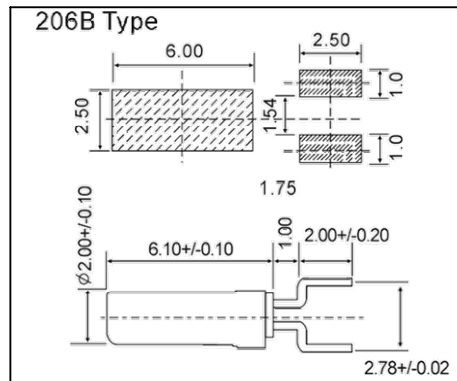
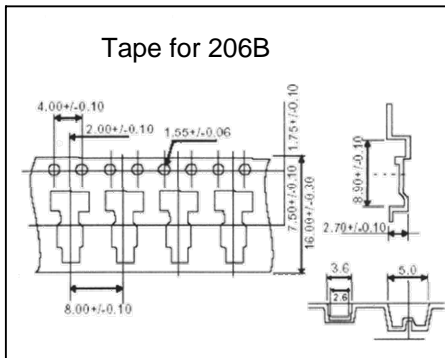

PART NUMBER SYSTEM

